

## Abstract

This application note discusses the control of a 3-phase brushless BLDC motor in Sinusoidal PWM Modulation mode using Zilog's Z16FMC family of microcontrollers (MCUs). The Z16FMC product family is designed specifically for motor control applications, featuring an on-chip integrated array of application-specific analog and digital modules. The result is fast and precise fault control, high system efficiency and on-the-fly speed/torque control, as well as ease of firmware development for customized applications.

This document further discusses ways in which to implement sinusoidal PWM modulation and phase-angle synchronization with Hall sensor feedback. The results are based on using a modified version of the Z16FMC Modular Development System (MDS) module, a 3-phase motor control (MC) application board, and a 3-phase 24VDC, 30W, 3200 RPM BLDC motor with internal Hall sensors.

- 
- **Note:** The source code file associated with this application note, [AN0351-SC01.zip](#), is available free for download from the Zilog website. This source code has been tested with version 5.0.1 of ZDSII for ZNEO MCUs. Subsequent releases of ZDSII may require you to modify the code supplied with this application note.
- 

## Features

The power-saving features of this Z16FMC application code include:

- Smooth motor start-up with reduced starting current
- 3-Hall sensor feedback sinusoidal PWM modulation
- Microcontroller-based overcurrent protection
- Adjustable speed and current (frequency and sine magnitude)
- Selectable control of motor direction
- UART interface for PC control
- LED to indicate motor operation
- LED to indicate UART control
- LED to indicate a fault condition

Figure 1 shows a block diagram of the Z16FMC MCU architecture.

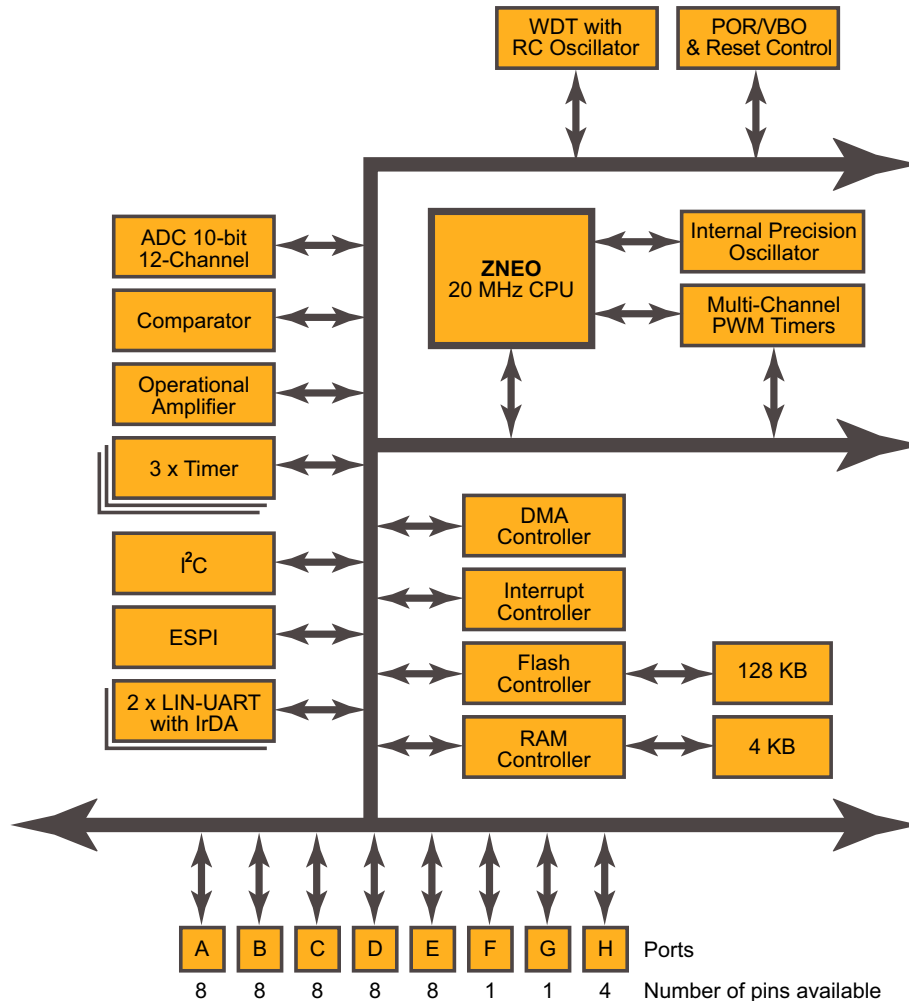

Figure 1. The Z16FMC MCU Architecture

## Discussion

The Z16FMC Series Flash microcontrollers upon which this Sinusoidal PWM driver has been conceived are based on Zilog’s advanced 16-bit ZNEO CPU core. The ZNEO CPU sets the standard for performance and efficiency, with up to 20MIPS performance at 20MHz. It supports 16-bit internal bus widths, and provides near-single-cycle instruction execution.

Up to 128KB internal Flash memory is accessible by the CPU, 16 bits at a time, to improve processor throughput. Up to 4KB of internal RAM provides storage of data, variables and stack operations.

PWM sinusoidal operation has certain advantages over block-commutated PMSM motor driving approaches, most notably its lower electrical and lower acoustical noise signa-

tures. By comparison, the block commutation method causes harsh current transitions through the PMSM motor coils, essentially turning the phase windings of the motor on and off between commutations. The PWM sinusoidal method does not create these harsh current transitions through the motor coils, because the current and phase voltages are sinusoidal in nature. Motors operating via the sinusoidal PWM method, however, typically run at a higher efficiency than block-commutated motors.

Because of the advantages of a PWM sine driver scheme's attributes, PWM sinusoidal operation may be a better option for certain applications in which the life of ripple capacitors and ball bearings are concerns, as well as electrical noise.

Sinusoidal PWM driving schemes can be used to drive either PMSM- or BLDC-type motors, however, to take advantage of a sinusoidal driving scheme, a PMSM-type motor is likely to show the best results due to its sinusoidal wound-phase wiring.

In each of the Z16FMC products, the novel device architecture allows for the realization of the following enhanced control features; each is described in this section.

- Time stamp for speed control
- Integrated operational amplifier
- Multichannel PWM timer

## **Time Stamp for Speed Control**

The Capture feature of the 16-bit timers can be used to take a time stamp of the Hall sensor's electrical timing periods. Upon a predefined Hall state, the asynchronously operating timer is read and its value is compared against a calculated speed reference value using PI closed loop control.

## **Integrated Operational Amplifier**

Appliance controllers almost invariably monitor motor speed by sensing current through the motor windings using sensor and sensorless techniques in conjunction with the ADC. Ordinarily, sampling instances by the ADC are synchronized by the MCU. With this process, an external operational amplifier is often used to convert the current signal to a voltage signal; the ADC next samples the voltage signal and outputs the result to the processor. The processor then synthesizes the PWM outputs to control motor speed. In the case of the Z16FMC family of microcontrollers, an on-chip integrated operational amplifier eliminates the requirement for an external component, thereby reducing overall system cost.

## **Multichannel PWM Timer**

Each Z16FMC MCU features a flexible PWM module with three complementary pairs – or six independent PWM outputs – supporting deadband operation and fault protection trip input. These features provide multiphase control capability for a variety of motor types and ensure safe operation of the motor by providing immediate shutdown of the PWM pins during a fault condition.

## Theory of Operation

In a brushless DC motor, the rotor is comprised of permanent magnets, while the stator windings are similar to those in polyphase motors.

Generally, there are two methods for determining motor position and speed: sensored control and sensorless control. In sensor-based control applications, the Hall elements are integrated into the motor and used to detect the position of the rotor for drive and sine wave synchronization. In contrast, sensorless control employs the detection of back-EMF (BEMF) signals, which are generated (induced) by specific phase windings to synchronize the timing of a control loop.

An inverter bridge is used to drive the PWM sine generated currents through the BLDC motor windings, as shown in Figure 2.

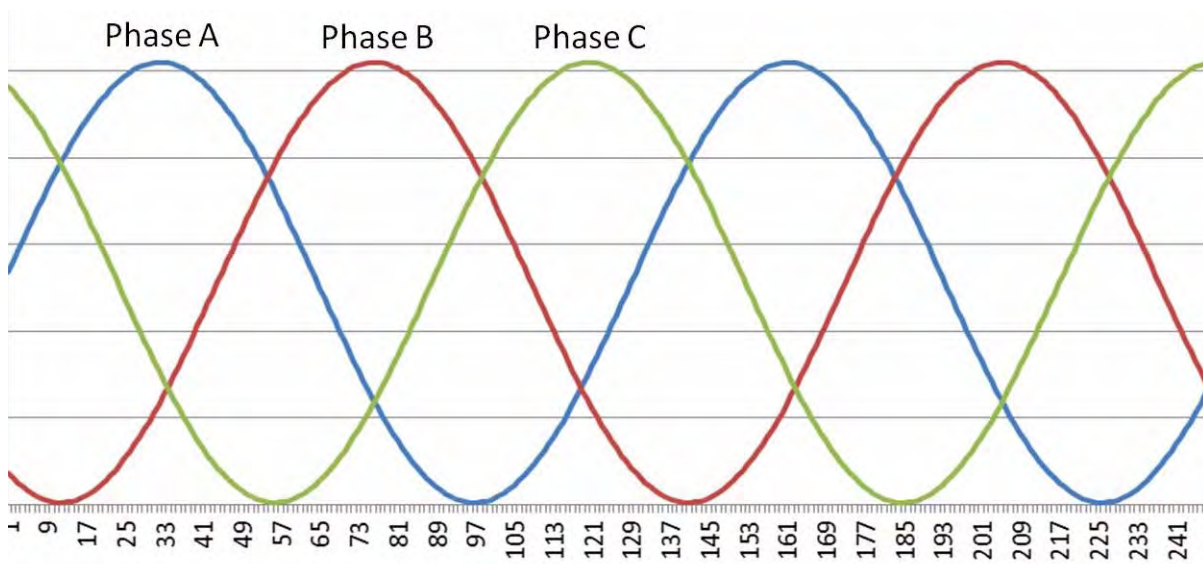

**Figure 2. 3-Phase BLDC Motor Control System**

The algorithm for Hall sensing is based on an implementation using three I/O ports which are configured for an *interrupt on edge* change of the Hall sensor's signals. One of the advantages of using Hall sensors is that the angular position of the motor is known upon startup of the motor, therefore minimizing erratic start-up behavior and the need for a start-up ramp until BEMF zero crossings are detected. The PWM duty cycle present at the motor windings then produces the torque to start the motor. The rotating motor generates the Hall signals that vector into a single I/O service interrupt routine, which determines the next commutation state.

Another advantage using Hall sensors as opposed to BEMF sensing is that under sudden and strong load increase, the information of the commutation angle is not in jeopardy of becoming lost. In sensorless feedbacks, an extreme load increase can cause an inductive spike – which results from the stored magnetic energy of the previously turned off phase –

to become wide enough to suppress the BEMF information. As a result, the commutation angle information may be lost and could cause the motor to stall.

The Hall sensor's angular position provides the information to energize all three phase voltages at the correct commutation angle. As opposed to trapezoidal or block commutation, in which two of the three phases are energized for each commutation step, the sinusoidal commutation requires all three phases to be energized for each commutation step, as shown in Figure 2.

To save computation time, the firmware implements a look up table in which the sine values are stored. The PWM timer interrupt service routine interrupts every 50µs and is used to fetch the sine values from the sine table and update the PWM sine frequency for Phase A, Phase B, and Phase C. This method provides very regular time intervals to update the sine frequency and scaling of the sine magnitude for all three phases. Right before exiting the PWM timer interrupt service routine, these three PWM channels are updated with the new PWM modulation values.

For this application, a PWM timer frequency of 20kHz was chosen to minimize linear switching power losses in the MOSFETs, and to be out of the audible noise range.

## PWM Frequency Calculations

Using every value in the 256 sine array, the frequency is:

$$\frac{1}{(\text{PWM period} \times 256)} = \frac{1}{50\mu\text{s} \times 256} = 78.125\text{Hz}$$

If every second sine value is used instead, then the frequency is effectively doubled and becomes:

$$\frac{1+n}{(\text{PWM period} \times 256)} = \frac{2}{50\mu\text{s} \times 256} = 156.25\text{Hz}$$

In this second equation, the numerator represents the 1 + nth number of an offset to the array elements; the larger the numerator, the higher the sine frequency. A better way of obtaining a wider sine frequency range and resolution of the sine wave is to use a 16-bit integer-type sine index of which only the upper byte is used to fetch the next PWM sine value from the look-up table. Depending on the frequency demand, the values of the upper byte can change with higher granularity, hitting each sine array value more or less times while the sine index continuously rolls over. Using this method, the lowest period using a 16-bit pointer to a 256-element sine table is:

$$65535 \times 50\mu\text{s} = 3.277 \text{ seconds}$$

Assuming the sine frequency is 60Hz, the offset value for the sine table pointer is:

$$\text{SineIndexOffset} = \frac{60 \times 65536}{20000} \approx 196$$

The resolution of the generated sine wave is a function of the sine frequency.

---

## Sine and Hall Commutation and Frequency Adjustment

Hall sensor interrupts are generated six times – once every sixty degrees – therefore providing data about the rotor position which is used to synchronize the sine wave commutation angle and frequency with the Hall commutation angle and frequency.

[Figure 2](#) on page 4 illustrates the generation of three 120-degree shifted sine waves based on values from a look-up table (LUT) which are then reconstructed in the PWM interrupt service routine.

## Speed Calculations

The angular period times of the rotor are captured every one-sixth of an electrical commutation, wherein Timer0 represents the number of timer ticks. These timer ticks are then compared against the demand speed coming from a potentiometer – also represented in timer ticks – and processed in a PI closed loop to adjust the look-up table values to change the frequency of the motor. If the motor is operated with open-loop speed control, then the speed demand coming from a potentiometer is used to directly generate the look-up table (LUT) values to change the motor frequency.

The angular speed calculation is:

$$\omega = \frac{d\phi}{dt}$$

In this equation,  $d\phi$  is the angular displacement and  $dt$  is the time taken for the angular displacement.

The position information is provided by the Hall sensor binary state, and the time between angular positions is measured by Timer0 timer ticks.

The frequency of a sinusoidal operated motor is calculated using the following equation:

$$F(\text{rotor}) = \text{RPM} * \frac{p}{120}$$

The rotor frequency becomes:

$$F(\text{rotor}) = \frac{p/2}{\text{Measured ticks} * \text{timer resolution} * \text{commutation steps} * 60}$$

RPM = (120\*f) / N, where N is the number of pole pairs.

Figure 3 illustrates how these calculations can influence a the PWM sine operation of a 3-phase BLDC motor.

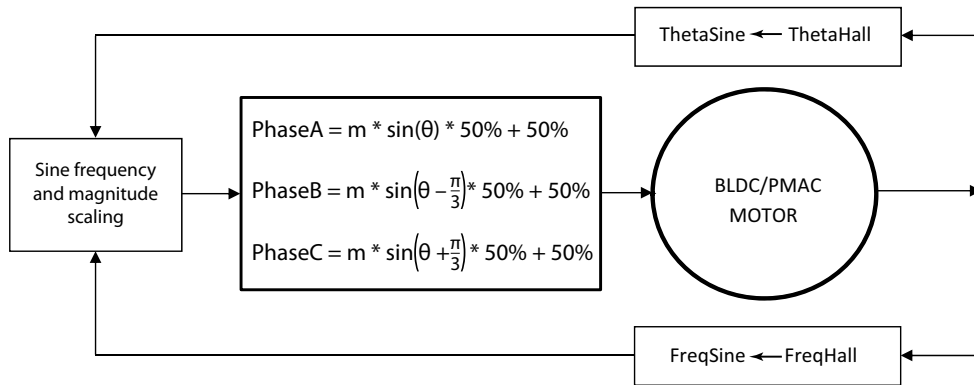

Figure 3. Simplified PWM Sine Operation of a BLDC Motor

The hardware used to realize the sinusoidal PWM motor driver approach discussed above is shown in the block diagram in Figure 4.

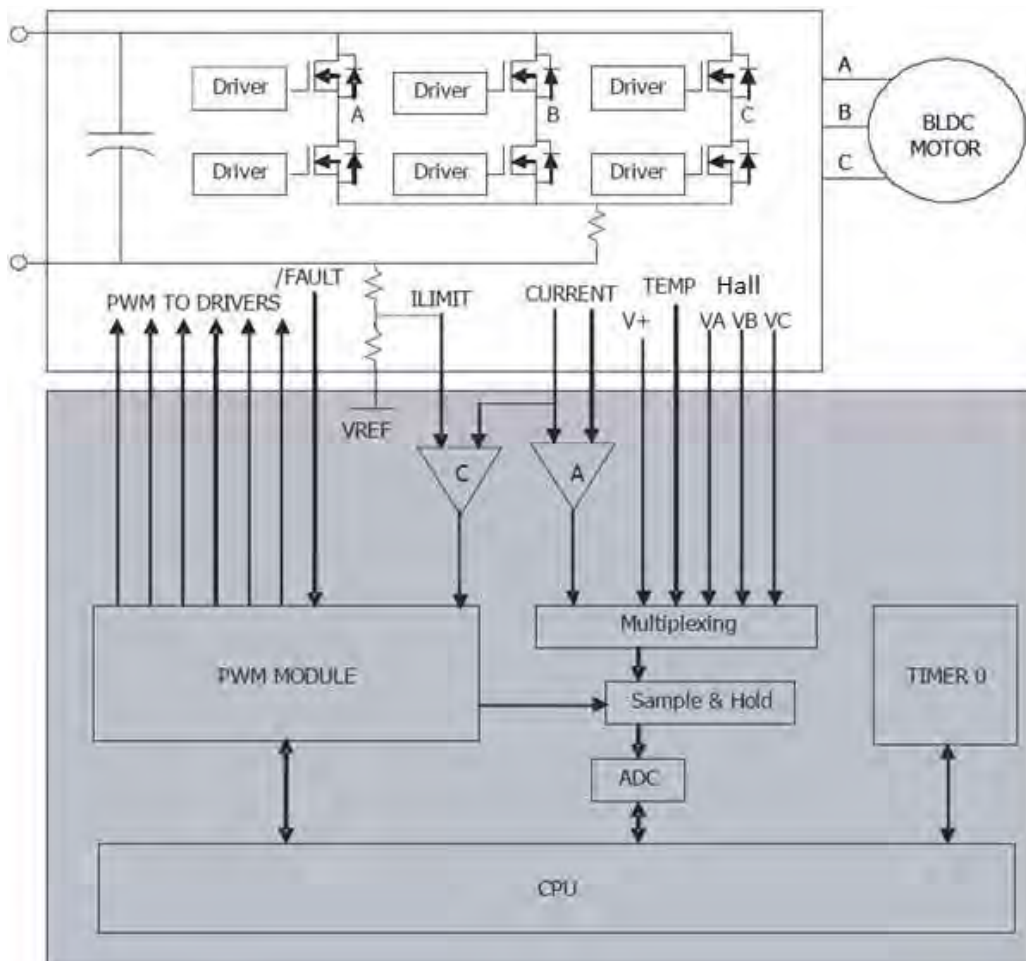

Figure 4. 3-Phase BLDC Motor Control System

## Overcurrent Protection

Currents can reach excessive amounts during startup, load changes, or catastrophic failures, for which a motor and electronics must be protected. A key feature of the Z16FMC MCU is the direct coupling of the on-chip integrated comparator to the PWM module to enable a fast, cycle-by-cycle shutdown during an overcurrent event. Oscilloscope-generated waveforms representing this sequence of events are shown in Figure 5.

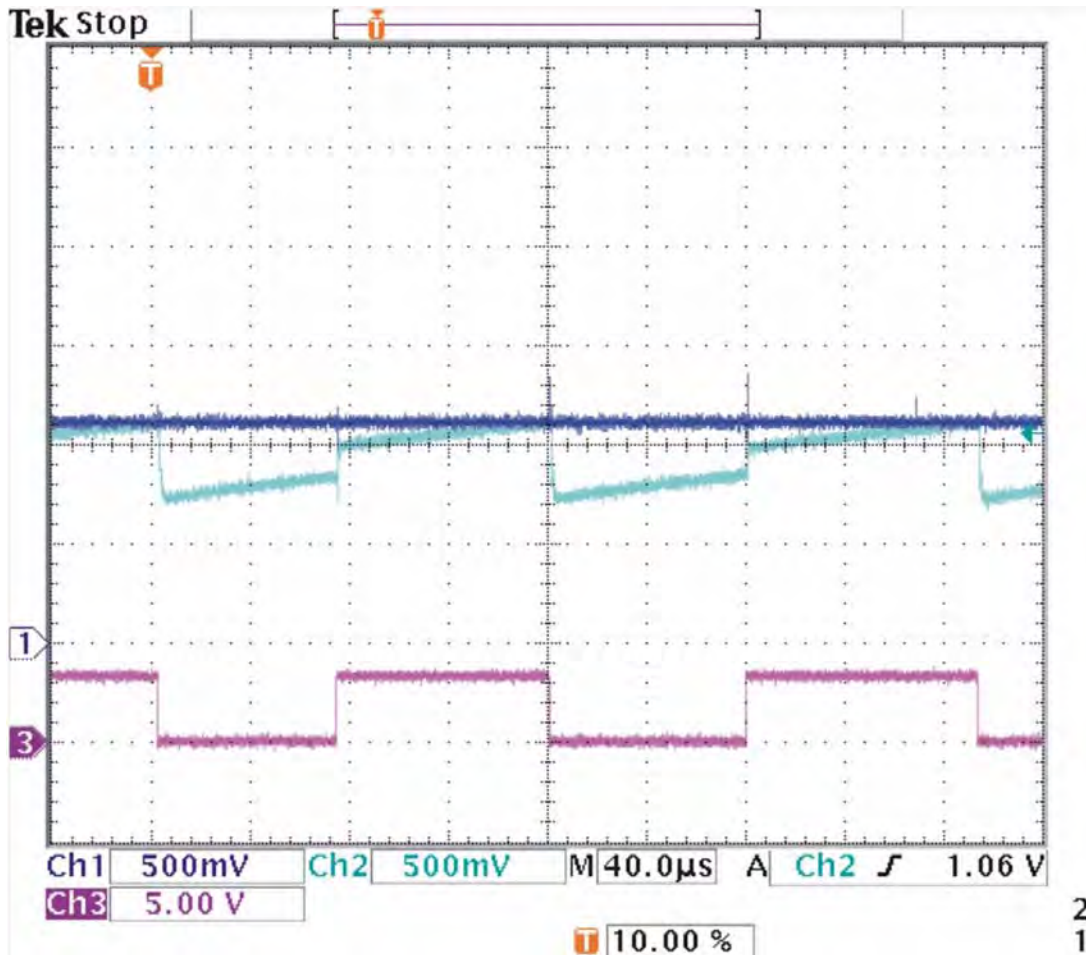

Figure 5. Cycle-by-Cycle Shutdown

- **Note:** To see additional schematic diagrams that may apply to this application, refer to the [Sensorless Brushless DC Motor Control with the Z16FMC MCU Application Note \(AN0311\)](#).



## Equipment Used

The tools and firmware used to operate this BLDC motor control application are listed below.

- Z16FMC Series Development Kit (Z16FMC28200KITG)
- Opto-isolated USB SmartCable
- ZDS II – ZNEO version 5.0.1
- PWM sine driver firmware ([AN0351-SC01.zip](#))
- 24 V power supply
- 30 W Linux BLDC motor
- Optional equipment:
  - Digital Oscilloscope or Logic Analyzer
  - Tektronix A6302 current clamp
  - 3.8 V/K<sub>RPM</sub> Class-F PMSM motor (Permanent Magnet Synchronous Motor)

## Testing Procedure

The motor control application code developed for this application was tested with a modified version of the 3-phase demo control module contained in the Z16FMC Series Development Kit. This module is shown connected to a Linux motor in Figure 6.

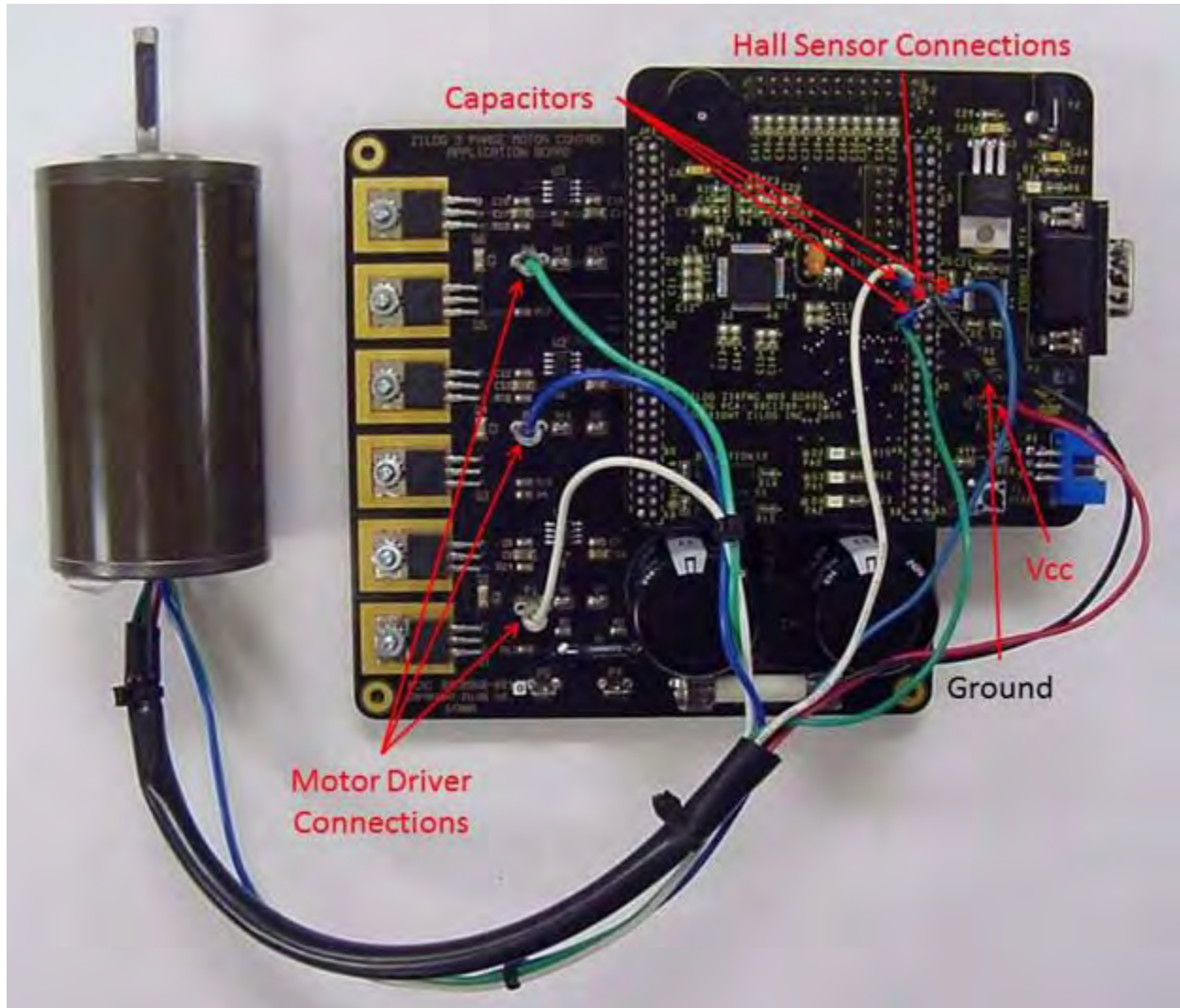

Figure 6. Demo Control Module with a Linux 30W BLDC Motor

## Connect the Motor to the Demo Control Module

To build, configure and test the hardware and firmware for this application, complete the following modifications. Refer to [Figure 7](#) on page 11 and/or to the schematic diagram in the [Sensorless Brushless DC Motor Control with the Z16FMC MCU Application Note \(AN0311\)](#) for assistance.

1. Connect the black Hall sensor supply wire to Ground (TP1).
2. Connect the red Hall sensor supply wire to V<sub>CC</sub> (TP2).
3. Connect the white Hall sensor wire to PD3 (JP2-25).
4. Connect the green Hall sensor wire to PD4 (JP2-26).

5. Connect the blue Hall sensor wire to PD5 (JP2-27).
6. Add a 680pF capacitor between each Hall sensor input and ground.
7. Connect the white motor phase wire to P1-A.
8. Connect the blue motor phase wire to P2-B.
9. Connect the green motor phase wire to P3-C.

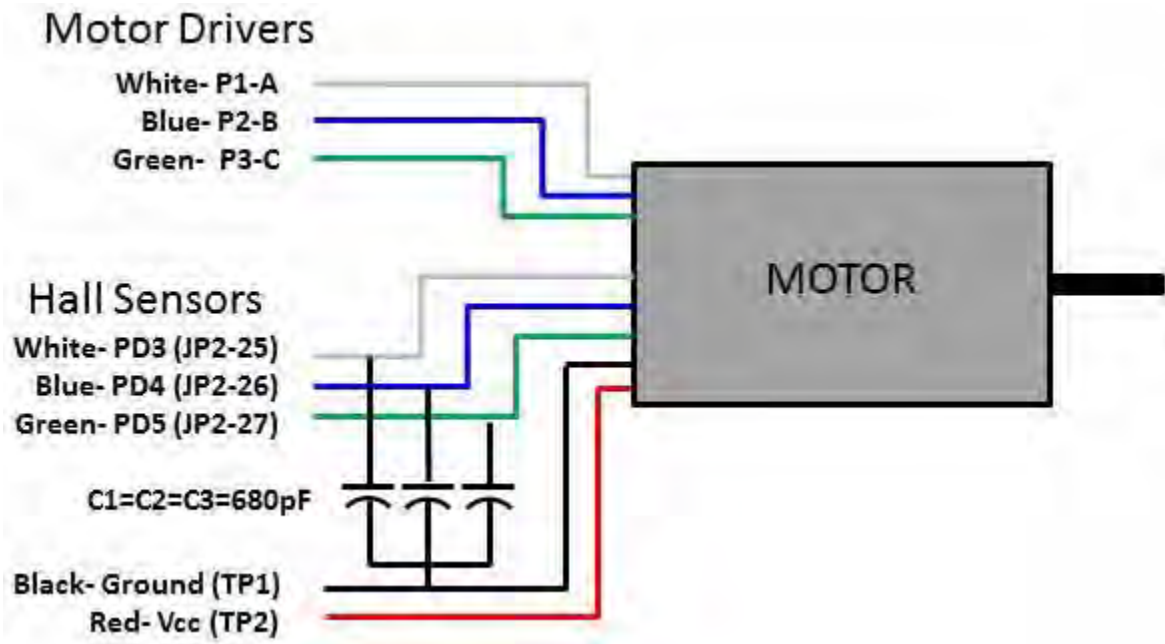

Figure 7. Motor Connections

- **Note:** The motor phase (20 gauge) wires are slightly wider in diameter than the Hall sensor (22 gauge) wires.

## Downloading and Running the Firmware

1. Download the [AN0351-SC01.zip](#) source code file from the Zilog website and unzip it to a convenient directory on your PC's hard drive.
2. Connect the opto-isolated USB SmartCable to the PC and to the Demo Control Module to P1 with the ribbon cable.
3. Launch ZDSII for ZNEO and open the project file that is contained in the AN0351-SC01 folder that you downloaded to your hard drive in [Step 1](#).
4. Compile and run the code on ZDSII.

5. Open a terminal emulation console such as HyperTerminal or Tera Term and configure it to the following settings:
  - 57600 baud rate
  - 8 data bits
  - no parity
  - 1 stop bit
  - No flow control
6. Connect the current probe clamp to one of the three motor phase wires to view the sine current.
7. Connect an oscilloscope probe between R9 and R10 on the Demo Control Module to view the sine voltage.
8. From the ZDSII toolbar, click the **Go** button in to start the motor.
9. Control the speed of the BLDC motor with the potentiometer located on the Demo Control Module.

## Results

Linux BLDC-type and Teknik/Hudson PMSM-type motors were tested to compare their corresponding voltage and current waveforms. During operation of the BLDC motor, three oscilloscope probes were connected to the Hall sensors, and a scope probe was connected to one of the three motor phase BEMF resistor dividers to show the three 120-degree shifted Hall sensors in conjunction with one of three sine wave phase voltages. The scope channel was set to AC so that the positive and negative half of the sine wave modulates with respect to the midpoint. These three voltages and one current waveform are shown for the BLDC and PMSM motors in Figures 8 and 9, respectively.

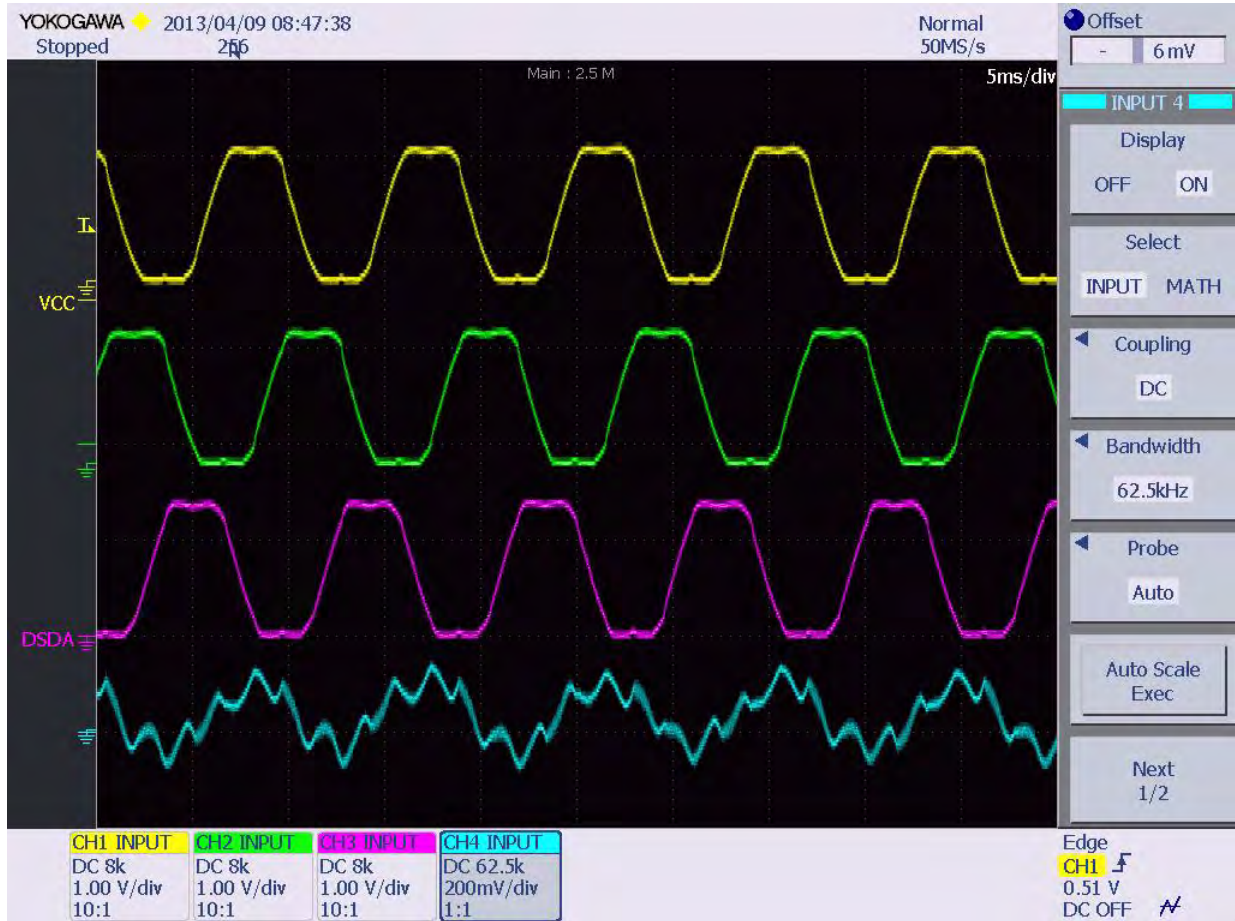

Figure 8. Linix BLDC Motor Phase Voltages and One Current Waveform

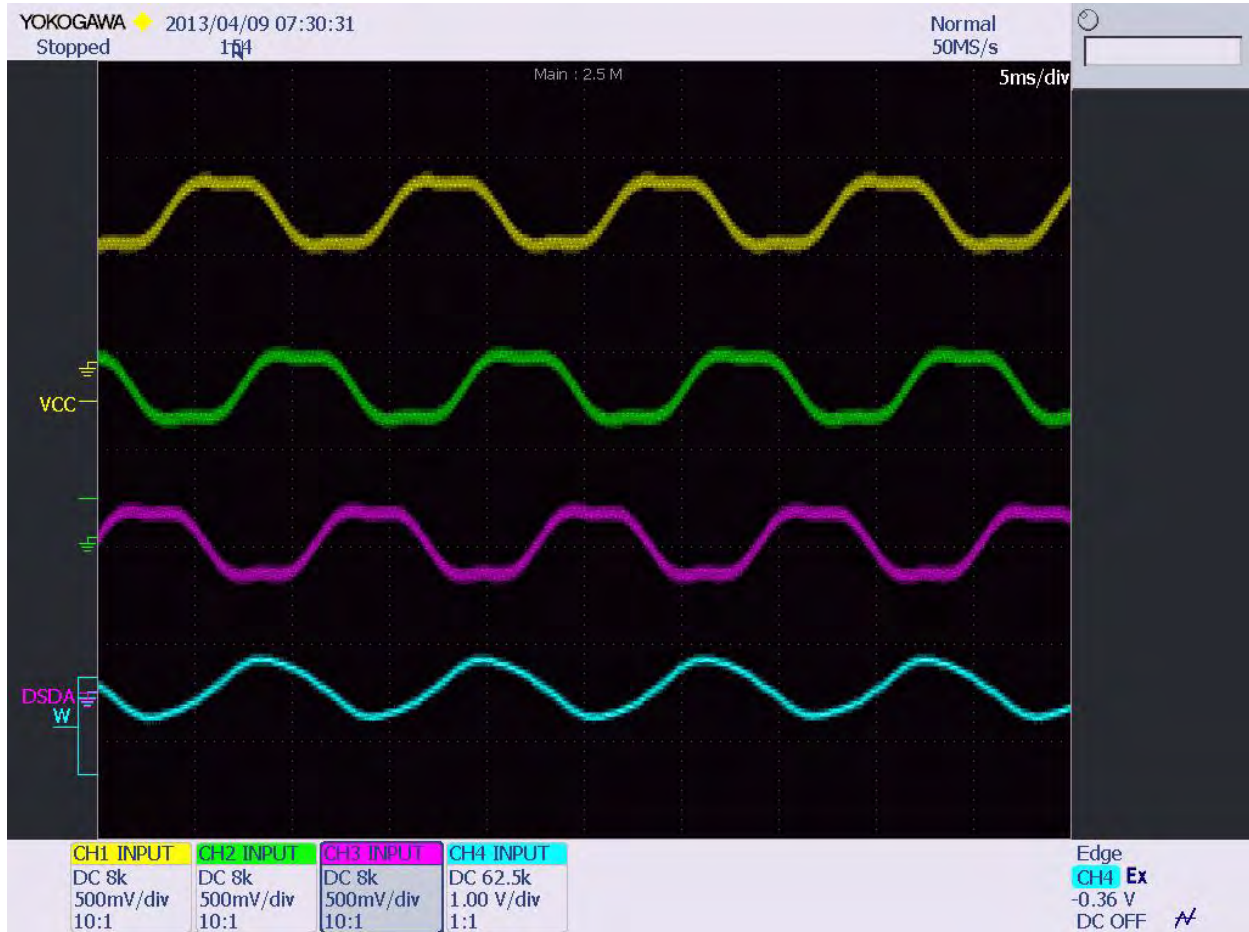

Figure 9. PMSM Phase Voltages and One Current Waveform

## Speed Control Performance in a Closed Loop

To monitor performance of the speed control function while operating in a closed loop, the motor speed was set to 2000RPM at a nominal operating voltage of 24V. As this operating voltage was increased and decreased by plus and minus 4V, motor speed was observed to remain constant. To test the PI loop under load, the motor load was increased, which caused the PI to quickly ramp up the current to maintain the set speed. PI loop stability was verified by observing the voltage sine wave while loading the running motor, a condition for which the sine wave period time must be maintained constant in both amplitude and frequency.

## Speed Control Performance in an Open Loop

To monitor performance of the speed control function while operating in an open loop, the motor speed was set to 2000RPM at a nominal operating voltage of 24V. As this operating voltage was increased and decreased by plus and minus 4V, motor speed was observed to

---

vary. Motor load was then increased, which caused the motor current to be increased while its speed slightly dropped.

## Summary

The purpose of this application was to demonstrate the operation of a BLDC or PMSM type machine using the sinusoidal PWM technique.

To generate sinusoidal voltages and currents 120 degrees apart for a BLDC machine, a sine look up table (LUT) was implemented to reconstruct the three sine waves and formulas have been shown to calculate the motor frequency. Since the frequency calculations include the PWM period, all sinusoidal wave constructions are executed in the PWM interrupt service routine. The execution time for the sine wave reconstruction in the PWM service interrupt routine takes 20 $\mu$ s. The execution time of the Hall interrupt service routine takes 30 $\mu$ s. Both execution times are based on a 20MHz external clock.

To maintain synchronization and commutation angle between the sine frequency and hall frequency, the Hall interrupt service routine captures the binary Hall state upon each interrupt and fetches the corresponding reference angle from a Look Up Table (LUT).

The high byte of the PWM sine Look Up Table index is used to fetch the next value from the Sine Look Up Table (LUT). Any offset value to the high byte of the PWM sine Look Up Table index will increase the frequency of the sine wave.

Sinusoidal PWM operation has the advantage of commutating the BLDC or PMSM with less acoustical and electrical noise, because the sine current through the windings has no steep current transitions. This allows for higher life expectancy of ripple current capacitor and ball bearings because the sinusoidal commutation approach causes no torque or current ripple in a PMSM or BLDC type motor. Besides electrical and acoustical noise reduction, the PWM sine approach also increases the efficiency in a BLDC-/PMSM-type motor. The efficiency can be further increased if a 3rd harmonic is injected into the PWM sine wave.

## References

The following documents are each associated with the Z16FMC Series of Motor Control MCUs; each is available free for download from the Zilog website.

- [Z16FMC Series Motor Control MCU Product Specification \(PS0287\)](#)
- [ZNEO CPU Core User Manual \(UM0188\)](#)
- [Z16FMC Series Motor Control Development Kit User Manual \(UM0234\)](#)
- [Z16FMC Series Motor Control Development Kit Quick Start Guide \(QS0079\)](#)
- [Zilog Developer Studio II - ZNEO User Manual \(UM0171\)](#)
- [Sensorless Brushless DC Motor Control with the Z16FMC MCU Application Note \(AN0311\)](#)

## Appendix A. Flow Charts

Figure 10 presents an algorithm by which a 3-phase BLDC motor can be controlled using the Z16FMC MCU. Refer to the [Sensorless Brushless DC Motor Control with the Z16FMC MCU Application Note \(AN0311\)](#) for related schematics.

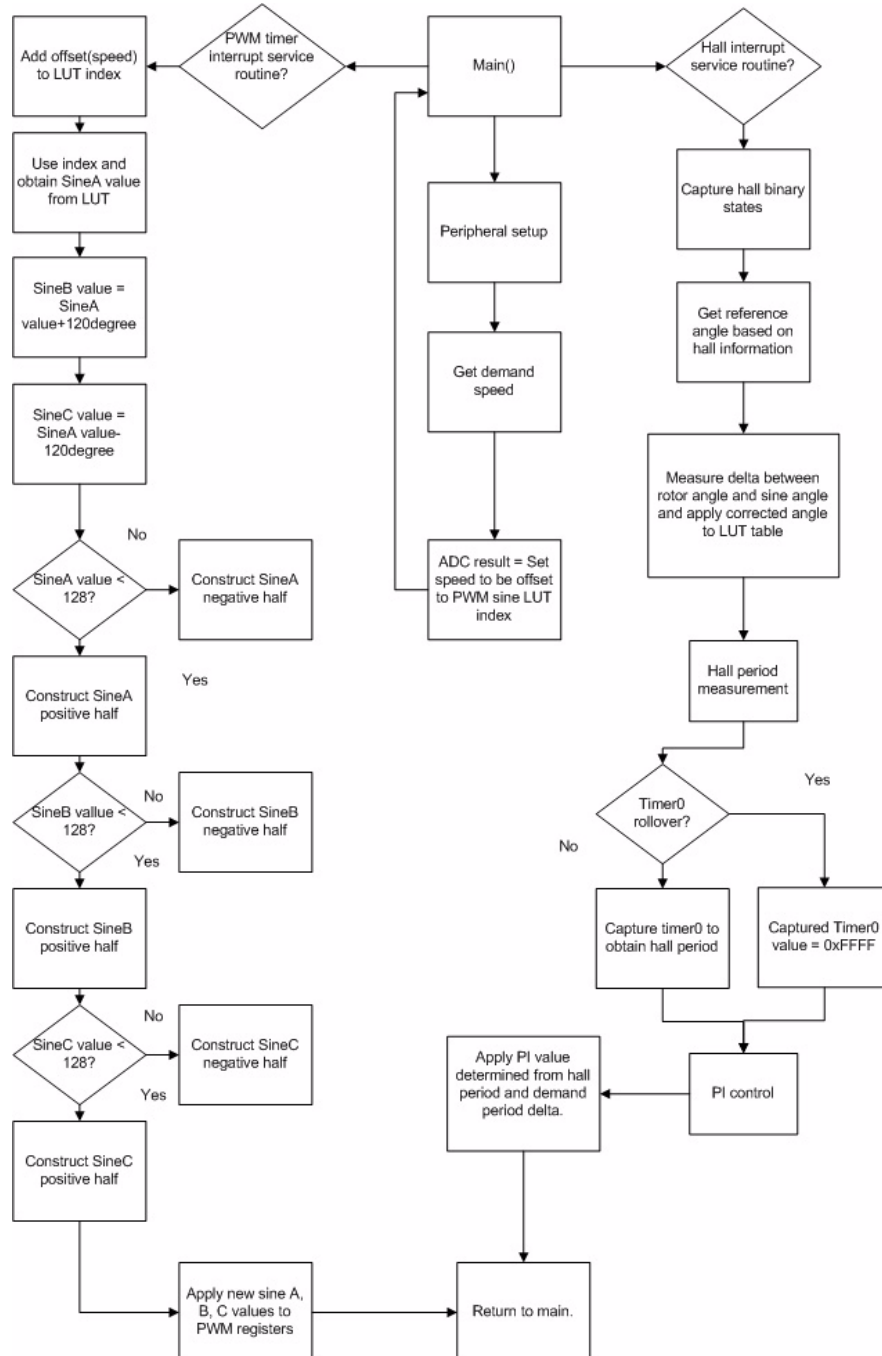

Figure 10. Simplified Control Algorithm



---

## Customer Support

To share comments, get your technical questions answered, or report issues you may be experiencing with our products, please visit Zilog's Technical Support page at <http://support.zilog.com>.

To learn more about this product, find additional documentation, or to discover other facts about Zilog product offerings, please visit the Zilog Knowledge Base at <http://zilog.com/kb> or consider participating in the Zilog Forum at <http://zilog.com/forum>.

This publication is subject to replacement by a later edition. To determine whether a later edition exists, please visit the Zilog website at <http://www.zilog.com>.



**Warning:** DO NOT USE THIS PRODUCT IN LIFE SUPPORT SYSTEMS.

---

### LIFE SUPPORT POLICY

ZILOG'S PRODUCTS ARE NOT AUTHORIZED FOR USE AS CRITICAL COMPONENTS IN LIFE SUPPORT DEVICES OR SYSTEMS WITHOUT THE EXPRESS PRIOR WRITTEN APPROVAL OF THE PRESIDENT AND GENERAL COUNSEL OF ZILOG CORPORATION.

#### As used herein

Life support devices or systems are devices which (a) are intended for surgical implant into the body, or (b) support or sustain life and whose failure to perform when properly used in accordance with instructions for use provided in the labeling can be reasonably expected to result in a significant injury to the user. A critical component is any component in a life support device or system whose failure to perform can be reasonably expected to cause the failure of the life support device or system or to affect its safety or effectiveness.

#### Document Disclaimer

©2013 Zilog, Inc. All rights reserved. Information in this publication concerning the devices, applications, or technology described is intended to suggest possible uses and may be superseded. ZILOG, INC. DOES NOT ASSUME LIABILITY FOR OR PROVIDE A REPRESENTATION OF ACCURACY OF THE INFORMATION, DEVICES, OR TECHNOLOGY DESCRIBED IN THIS DOCUMENT. ZILOG ALSO DOES NOT ASSUME LIABILITY FOR INTELLECTUAL PROPERTY INFRINGEMENT RELATED IN ANY MANNER TO USE OF INFORMATION, DEVICES, OR TECHNOLOGY DESCRIBED HEREIN OR OTHERWISE. The information contained within this document has been verified according to the general principles of electrical and mechanical engineering.

Z16F and ZNEO are trademarks or registered trademarks of Zilog, Inc. All other product or service names are the property of their respective owners.